

# DRILLTEQ H-330

Two in one. 6-sided processing.  
CNC Processing Centers

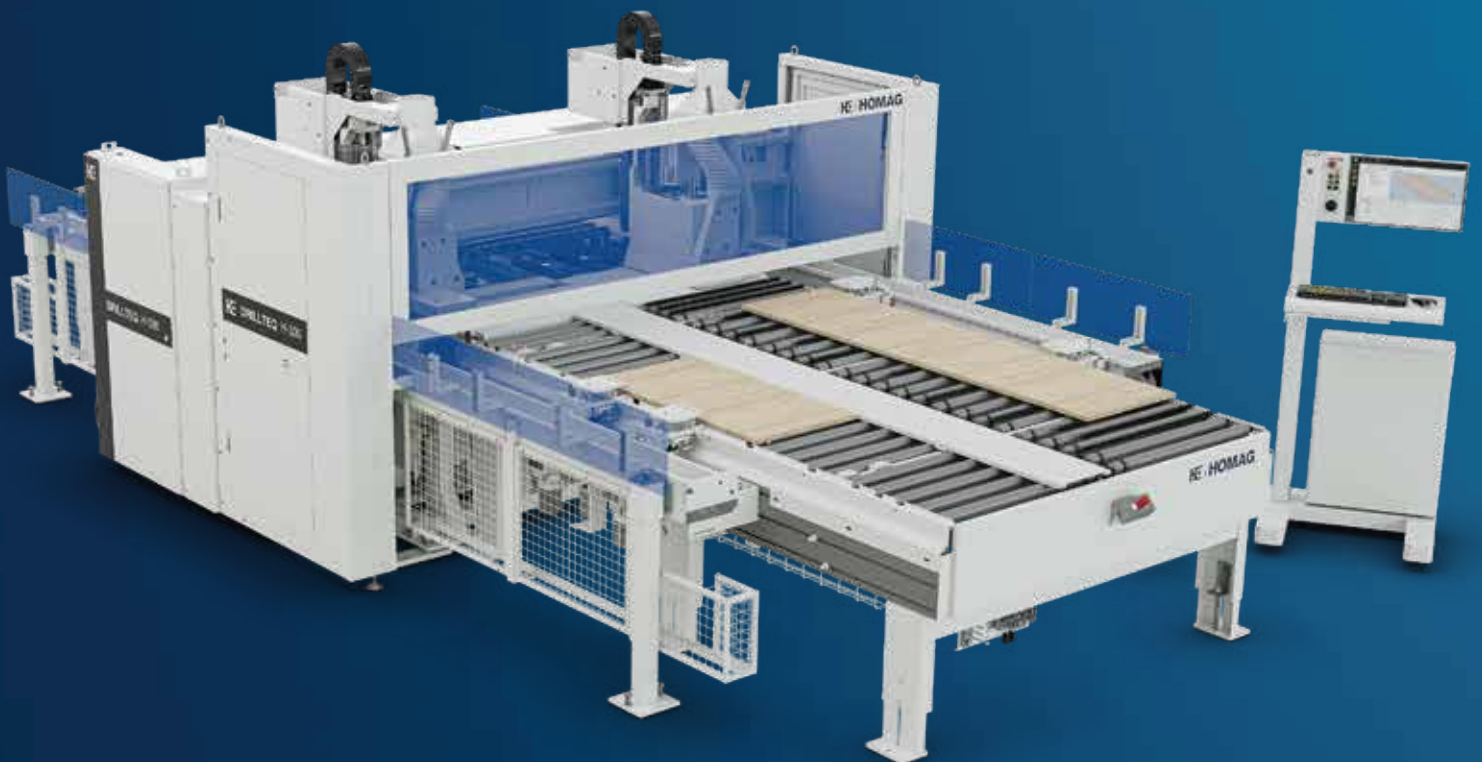





## DRILLTEQ H-330 – 6-sided processing

The DRILLTEQ H-330 impresses with speed and precision - in workpiece handling as well as in machining. Every drilling and milling operation is set with extreme repeat accuracy. The workpiece surfaces are perfectly protected despite fast processing speeds.

The possibility of processing two workpieces at the same time results in double efficiency and the versatile connection options of the machine bring high flexibility.

**[www.homag.com](http://www.homag.com)**

### CONTENTS

- 04 Networked worldwide
- 06 Quality
- 08 6-sided-processing at its best
- 10 Optional equipment
- 12 Simple operation - double output
- 14 Drilling
- 16 Comprehensive safety concept
- 18 Discover the connectivity options
- 20 powerTouch
- 22 Software
- 23 HOMAG China
- 24 Life Cycle Services
- 27 Technical data

## Networked worldwide – HOMAG is always at your side

INDIVIDUAL CUSTOMER WISHES, DEMANDING PRODUCTS AND A WIDE VARIETY OF MATERIALS – the needs of your customers are constantly growing. And this means that the challenges for you and your production grow too. Our aim is to offer you the solutions you need to

accommodate the desire for individuality. To produce flexibly and efficiently and set trends in the industry. We support wood processing businesses of any size on their way to the top. With machines and technologies that grow with you – including the right software solutions and service.



German Headquarter in Schopfloch



### **Everything from a single source.**

HOMAG meets all the requirements and wishes for the machines you have today. Handling systems, panel dividing technology, format and edge processing, drilling systems, sanding technology, spray coating and laminating technology, automation systems and software form a complete and innovative range of products and services. You benefit from a high degree of precision, performance and the right technology to ensure absolute flexibility, which you can use to optimize your entire production capacity.

### **Perfection can be programmed.**

The software solutions from HOMAG optimize processes in small and medium-sized enterprises and global industrial manufacturers of furniture. From the first sketch to the final product – our software solutions are perfectly adapted to HOMAG machines. They create efficiency and reliability in the order and production process.

### **HOMAG Life Cycle Services**

The sale of our machines comes with all-in optimum service backup and individual advice. We support you with service innovations and products which are especially tailored to your requirements. With short response times and fast customer solutions we guarantee consistently high availability and economical production – over the entire life cycle of your machine.



**HOMAG a global player**  
Production, sales and service network

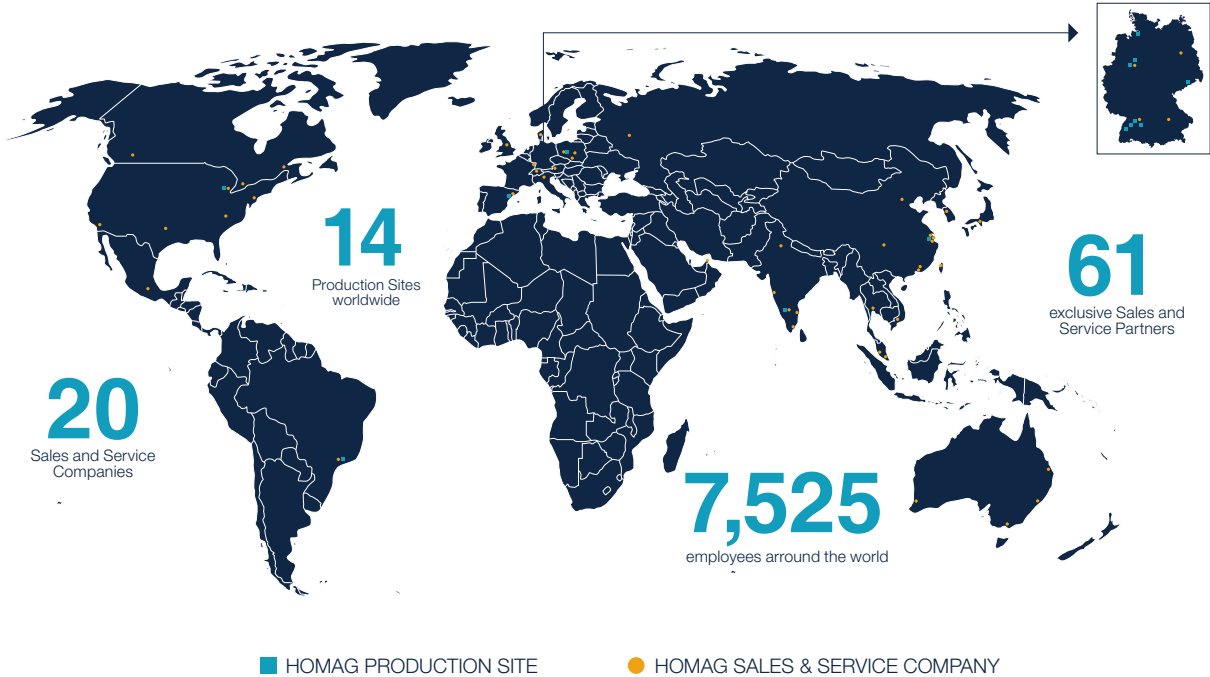

**International and expert.** With sales partners in over 100 countries, HOMAG has a global presence and is able to offer you a strong partnership. We make your company competitive and your business success long-lasting.

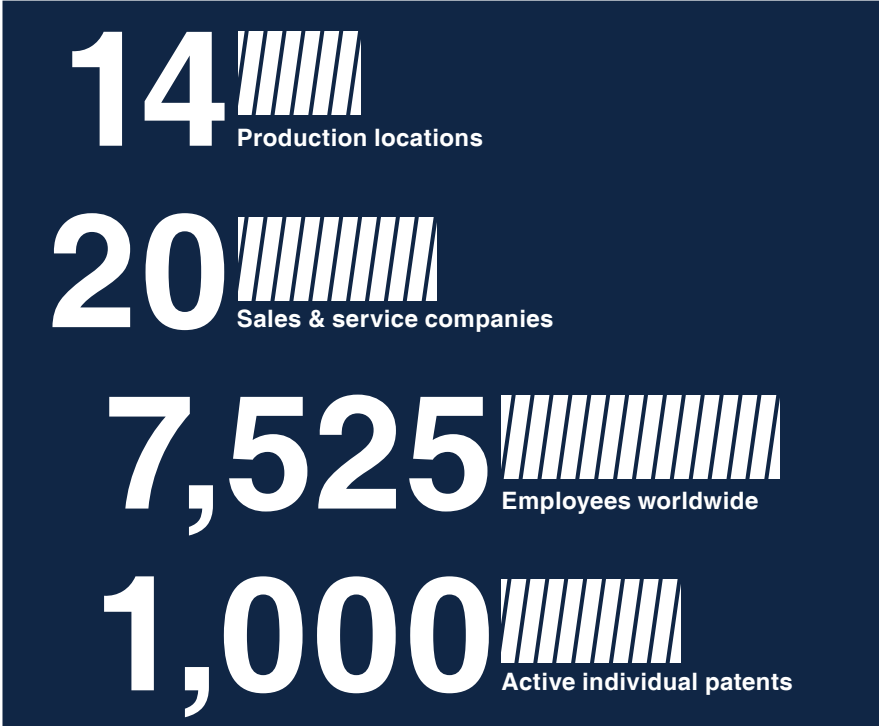



Proven technologies developed in Germany have naturally been applied to this machine series. We as HOMAG Group stand for high quality and technical availability of this model series. Your customers will feel the added value.

Werner Brinkhaus  
Director Product Management CNC Processing



**We stand  
for the quality...**

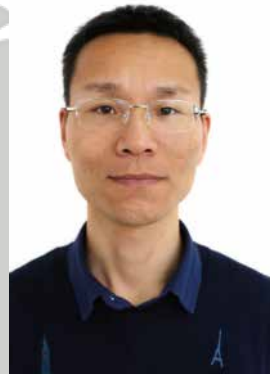

German standards make working with this machine very comfortable and additionally safe in operation. Standard safety features such as fences or covers are installed to protect everybody involved, because they are important to us!

Ivan Gao  
Manager Product Development & Order Engineering



**...with our name!**



HOMAG's experience and quality is our insistence and commitment. Customers will realize the value from every detail of HOMAG machine, no matter whether as the single or integration into a cell.

Gordon Wu  
Product Development & Order Engineering

## DRILLTEQ H-330 – 6-sided-processing at its best

Operation on two working fields for a continuously processing of panels. Two at top and two at bottom drilling blocks with 66 high-speed drilling spindles and optional routing motors, all in HOMAG Quality, realize precise Processing and a high level of flexibility.



### CNC-controlled clamping system on both sides

- Quick and precise – no setting times
- Workpiece thickness up to 40 mm



### High Speed Processing Unit | Top Head | HighSpeed 7500

- Left side V13, H6X, H6Y, Optional router 3.5KW or 4.5KW
- Right side V13, H6X, H6Y, Optional router 3.5KW or 4.5KW





**FULL PANEL PROCESSING...**

Routing and Drilling units perform in highspeed. 6 sided-processing along 2 working fields

**EVERYTHING UNDER CONTROL...**

4 CNC-controlled clamping devices ensure permanently firm and precise positioning of the workpieces – regardless of the speed

**EASY HANDLING...**

Even workpiece dimensions of Length 250-3000 and width 60(40)-1250 mm (2 x 620 mm) are easy to handle

**PRECISE IN DEPTH...**

The patented spindle clamp ensures an always accurate drilling depth for all drilling

**CONSTANTLY AT TOP LEVEL...**

The closed straight guiding system is protected against dust and dirt and thus very durable

**MORE PROCESSING POSSIBILITIES...**

Optional top electric spindles with automatic tool changer make processing more possibilities.



**High Speed Processing Unit | Bottom**

- Left side V8, Optional router 3.5KW
- Right side V8, Optional router 3.5KW

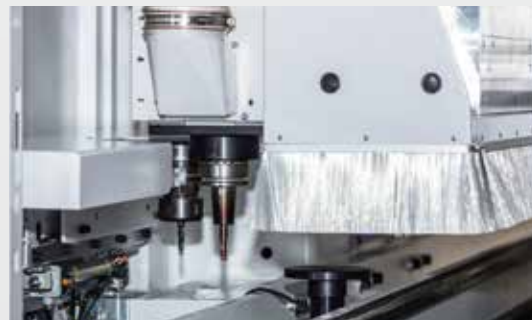

**Tool Change System (Option)**

- Electric Spindle with HSK F63
- 4-fold linear tool changers installed at machine sides

## Perfectly matched to you – The right equipment for your needs

**IN PERFECTION!** The configuration variety of the drilling equipment for the DRILLTEQ H-330 provides all possibilities regarding your requirements.

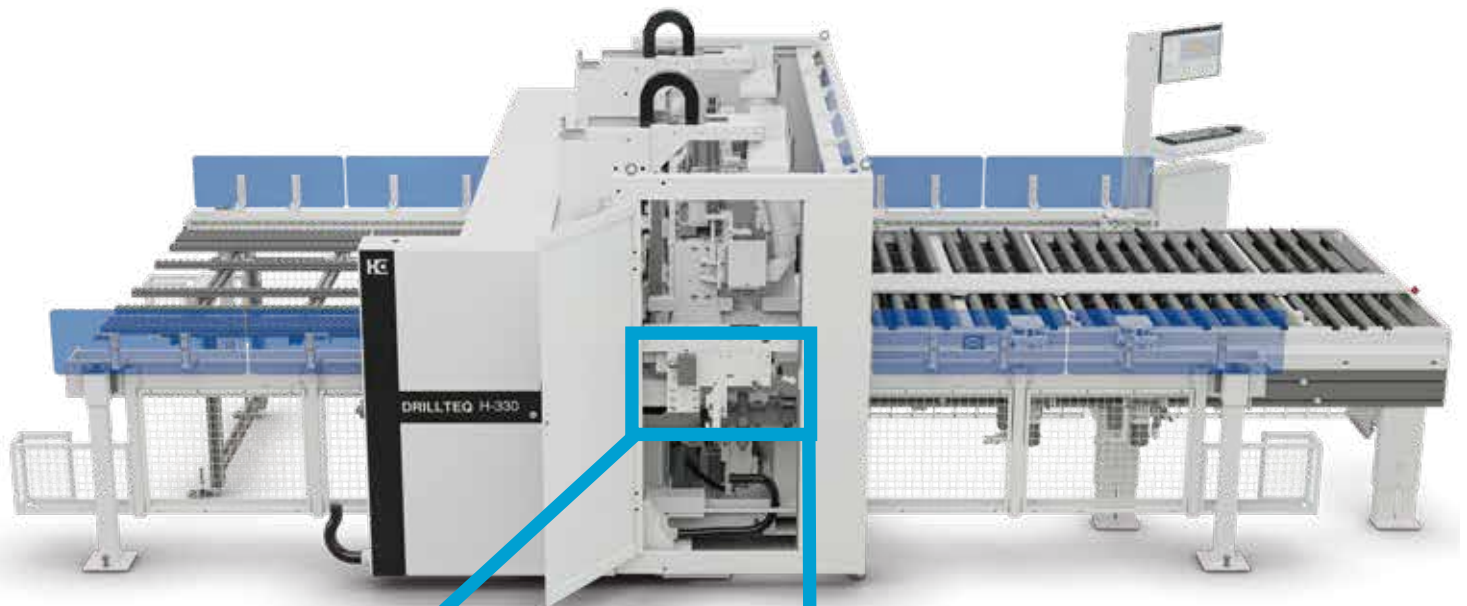

DRILLTEQ H-330 optionally equipped with automatic tool change system provides you with more processing possibilities

### **Tool Change System**

- Spindle with HSK F63
- 4-fold linear tool changer
- Optionally mounted at the left or right of machine
- Convenient and automatic exchange of tools from sides.
- Tool length control: tool length is queried and compared with the integrated tool database

# Optional equipment

**WITH THESE ACCESSORIES** you can further optimize and automate your machine.

## Classic Package - double labour efficiency

- Each workpiece is concretely identified for further part flow by means of barcode
- Basis for faster part flow with higher process quality
- In-feed with air-cushion table and out-feed with support table

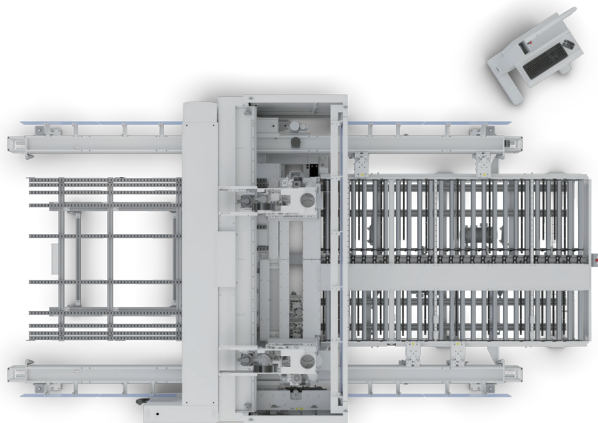
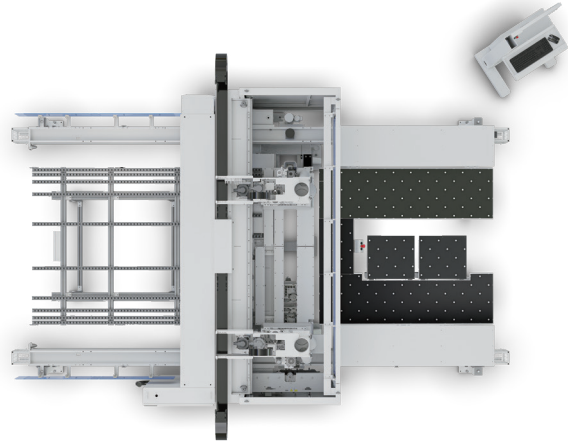

## Advanced Package - reduce labour effort

- Each workpiece is concretely identified for further part flow by means of barcode
- Virtual zero point can be set within the software
- Basis for faster part flow with higher process quality
- In-feed with drive roller conveyor and out-feed with support table
- Interface for Link to HOMAG simple automation

## Premium Package - Automate your processes

- Each workpiece is concretely identified for further part flow by means of barcode
- Virtual zero point can be set within the software
- Basis for faster part flow with higher process quality
- In-feed and out-feed with roller conveyors and the necessary hardware
- Interface for Link to HOMAG simple automation

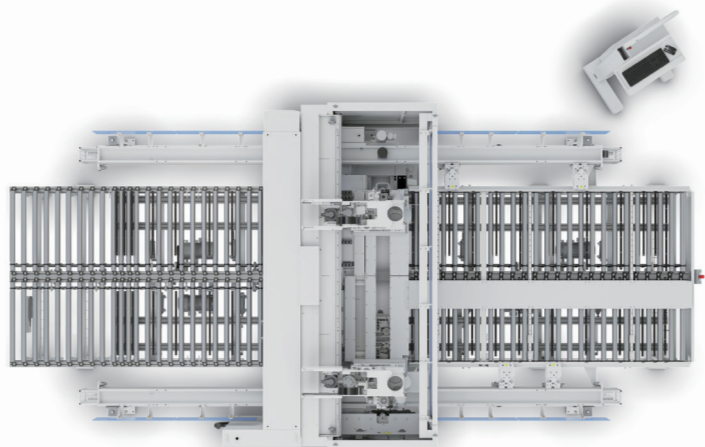

## Simple operation - double output - save time

By feeding two work fields at the same time, the DRILLTEQ H-330 offers virtually two machines in one. While production is running on one work field, the workpiece can already be prepared for seamless further processing on the second. This guarantees high availability and highly flexible production. The machine running time can be extended up to almost 75%. Work interruptions such as breaks or downtimes are reduced to a minimum.

Whether flexibility for high variant diversity through batch size 1 production or efficiency through series production - the DRILLTEQ H-330 offers the right solution for you.



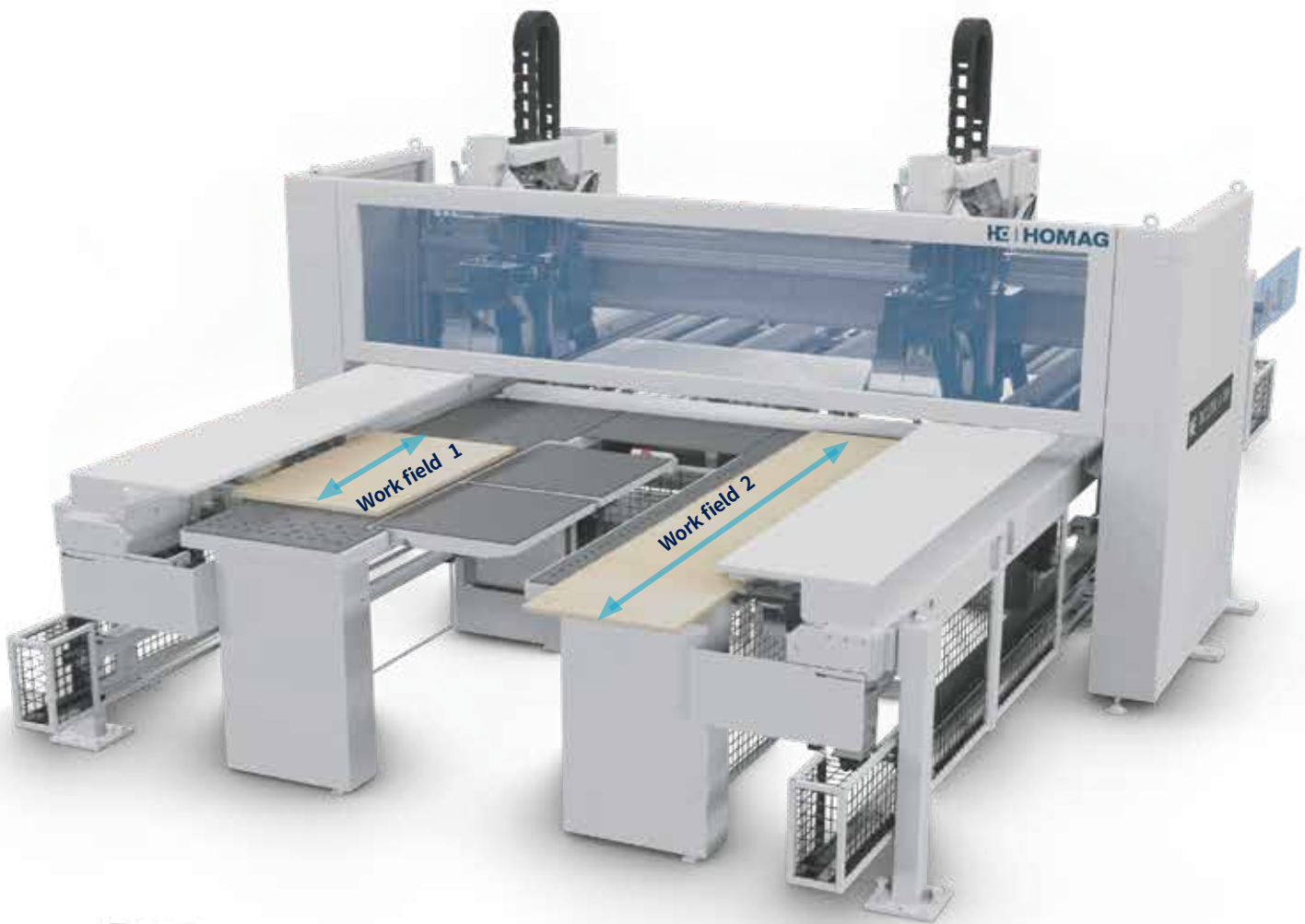

**“The possibility to use the two working fields at the same time, thus double loading the machine, is fully in line with the wishes and needs of the Chinese market. We always listen to our customers and convert this for their benefit.”**

Gordon Wu, Product Development

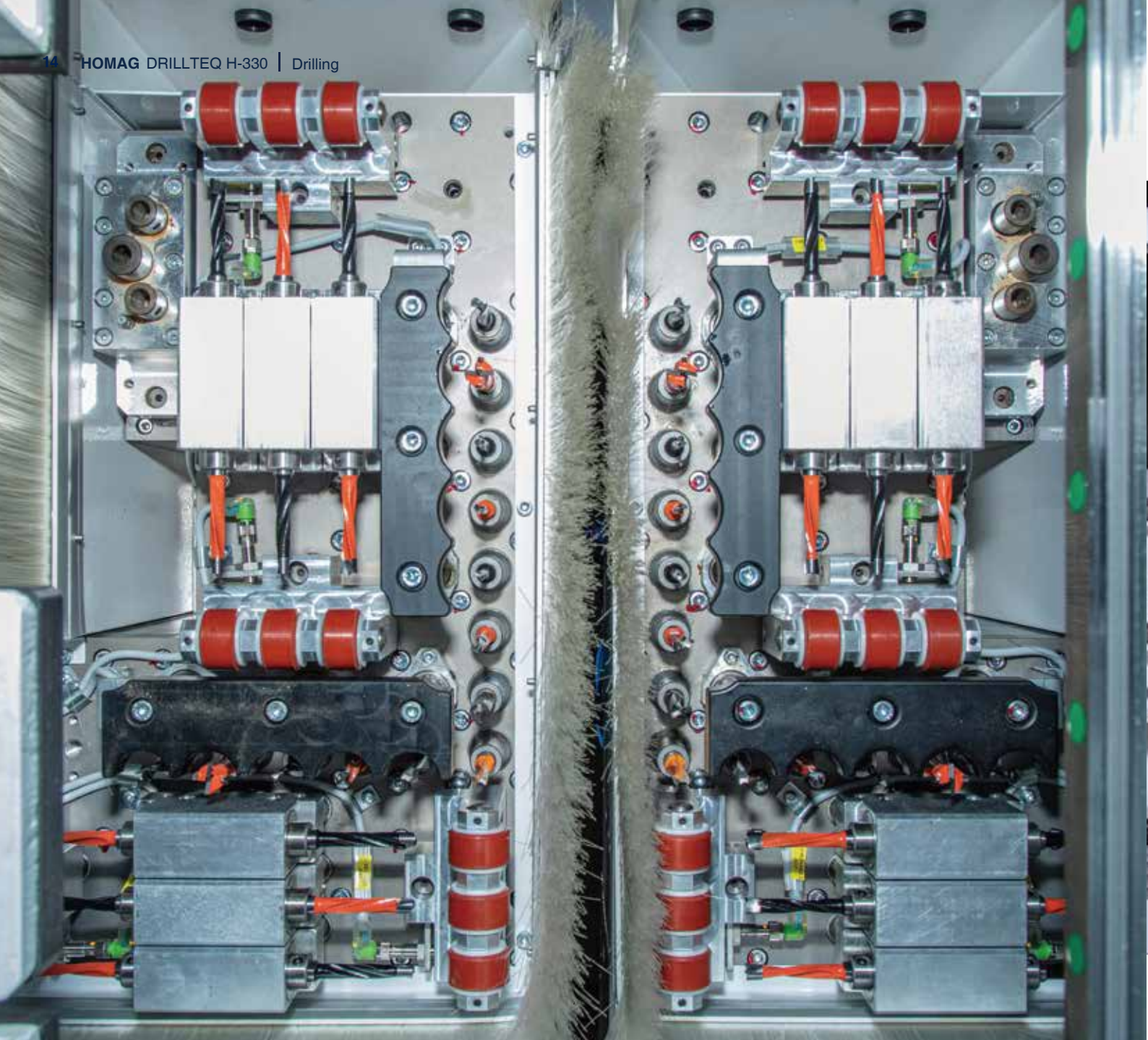

# 66

## Configuration 66-spindles

- 2 x 13 upper vertical drilling spindles
- 2 x 8 lower vertical drilling spindles
- 2 x 12 horizontal drilling spindles
- 2 x Higer D (optional)
- Optional 3,5 kW routers or 4.5 kW spindles with tool change system



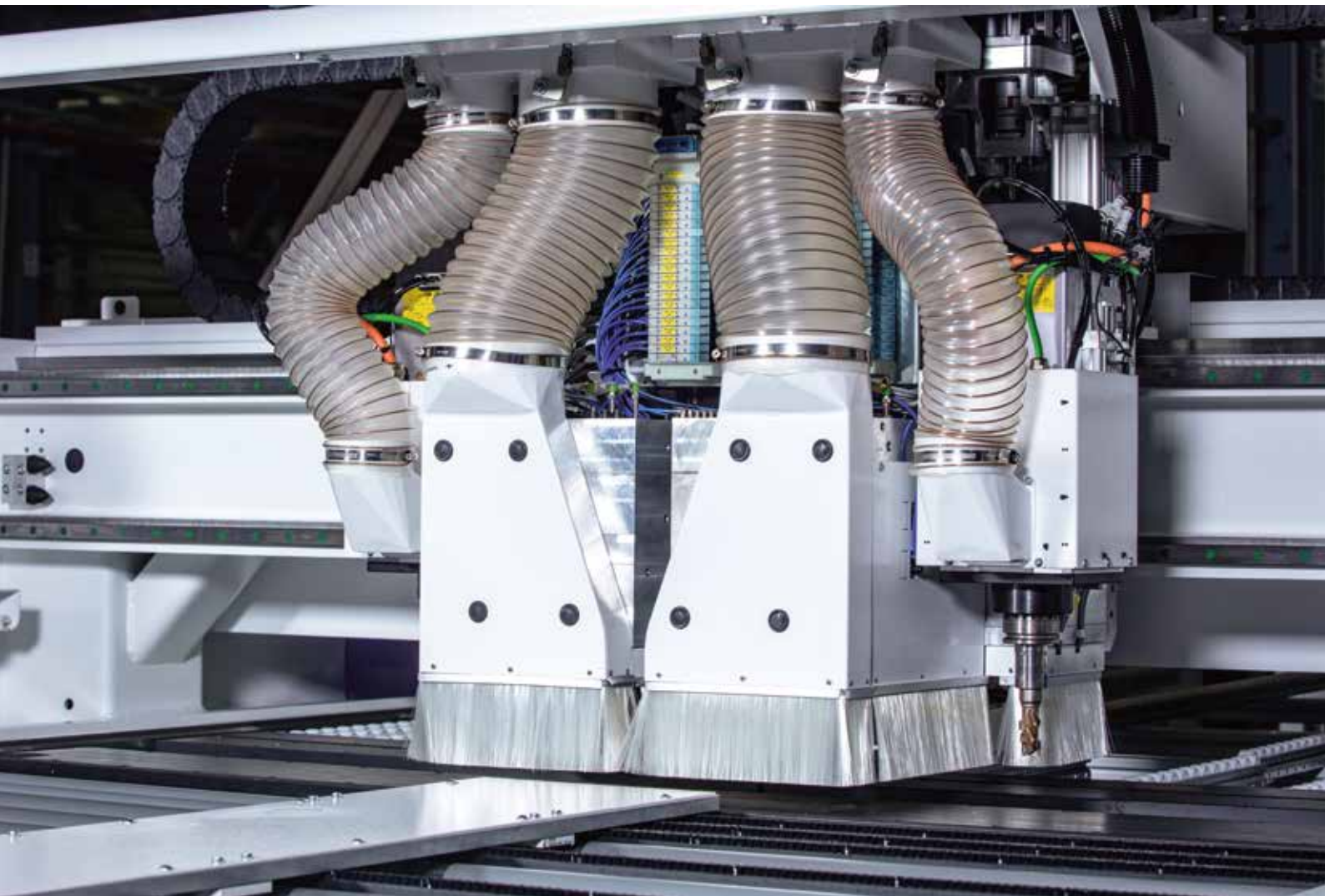

## Patented drilling technology – Our experience is your added value

Long service life, low wear and maximum precision. The patented German drilling technology of the HOMAG Group is already included in the DRILLTEQ as standard. It ensures you the highest quality of workmanship in the long term, which does not lose any of its high quality even with thousands of drilling operations per year.

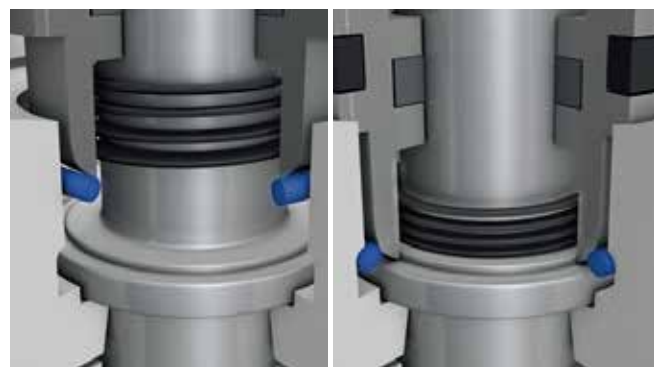

### Automatic spindle clamping

- Patented system
- Always exactly the same drilling depth – irrespective
- Constant quality by high repeat accuracy

## Safety first, because operator's safety is always important! Comprehensive safety concept

The DRILLTEQ H-330 has a comprehensive safety concept. German standards make working with this equipment not only comfortable, but also safe to handle.



The clamps on both sides are fast moving.  
The upper safety fence protects the processing area from the sides.





The lower safety fence prevents entry into the working area.

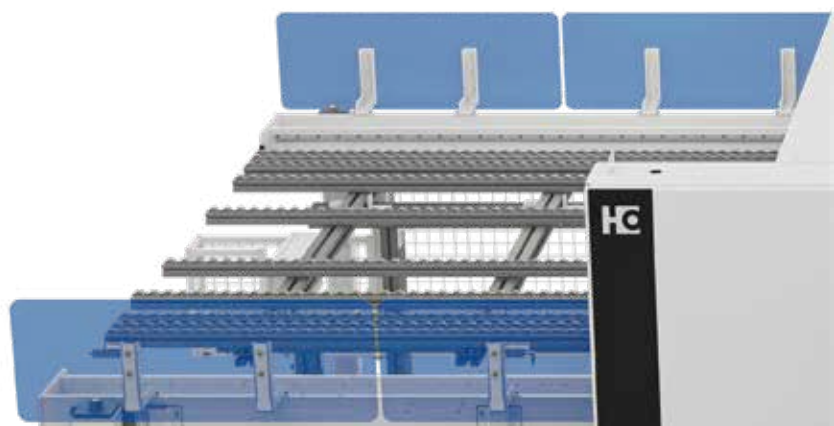

The Protective cover closed the processing area, to ensure the operator safety during the processing (avoid personal contact with machining tools and moving parts).

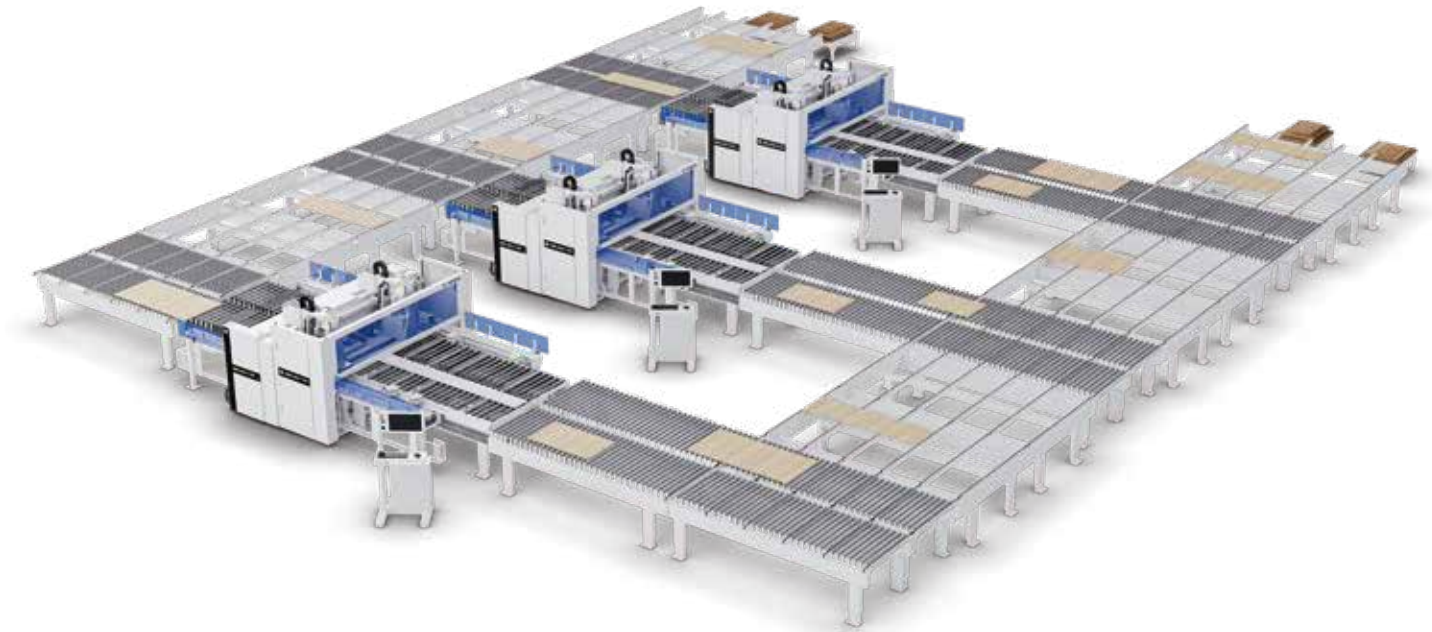

**3x DRILLTEQ H -330 networked**

The three machines match each other perfectly. Full process reliability and continuity is guaranteed.

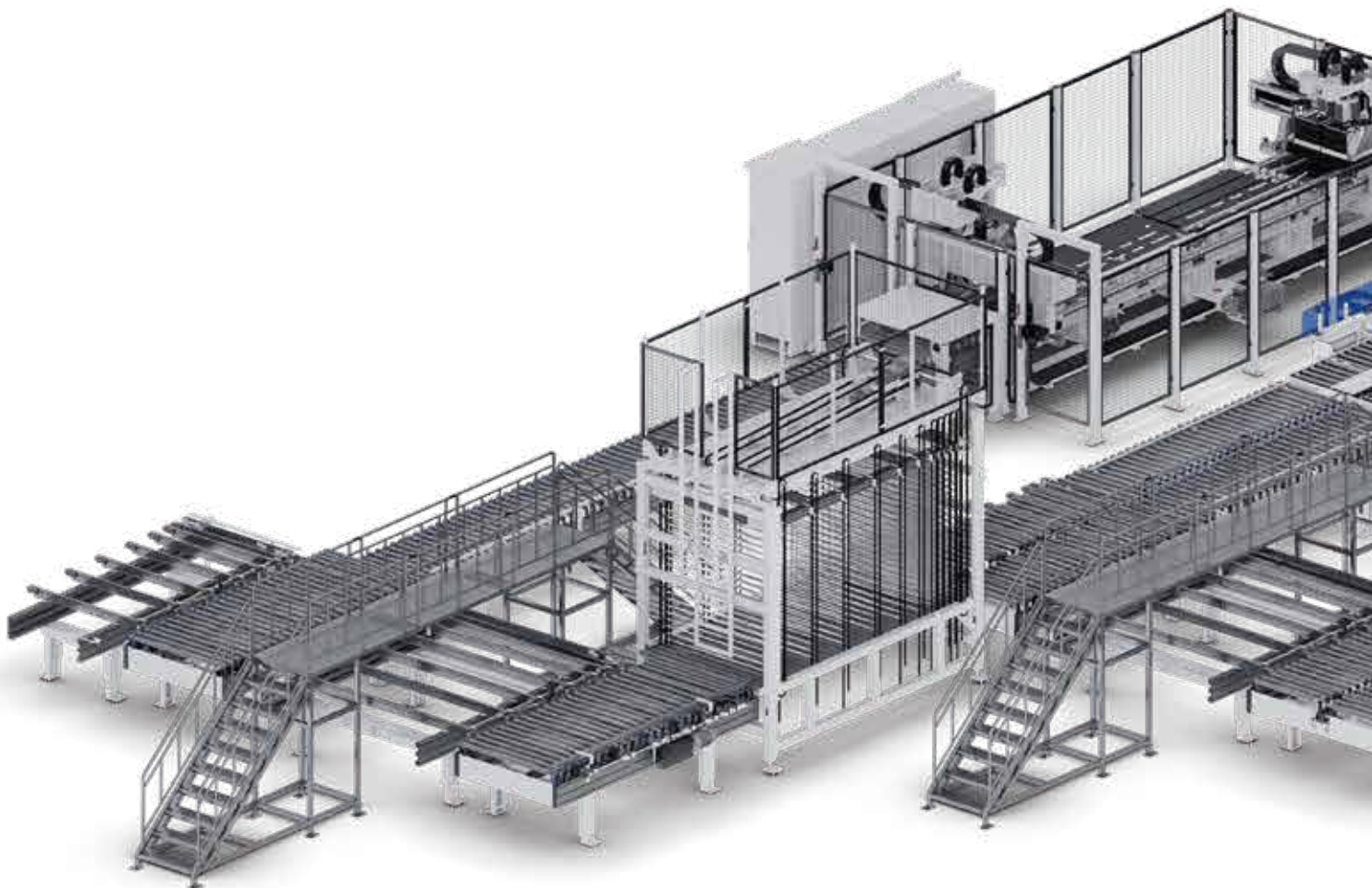

## Connected cell concepts – solutions both for you

Each cell in particular is an ideal solution for efficient panel processing in furniture manufacturing.

With these solutions, we show possible variants of how the added value of manually operated DRILLTEQ H-330 can be increased through automation. The systems are controlled by the ControllerMES. The production control system focuses on networking and the efficient design of production processes!

These two solutions can be easily integrated into your workshop. Choose the automation you need.

### YOUR BENEFITS AT A GLANCE

- Cost reduction - reduction of personnel expenses
- High availability - Machine uptime can be extended to nearly 100%.
- Highly flexible production - no need to train new processes
- Low maintenance operation - 24/7 availability (no vacation, breaks)
- Consistent high quality - No reduction/change due to staff changes

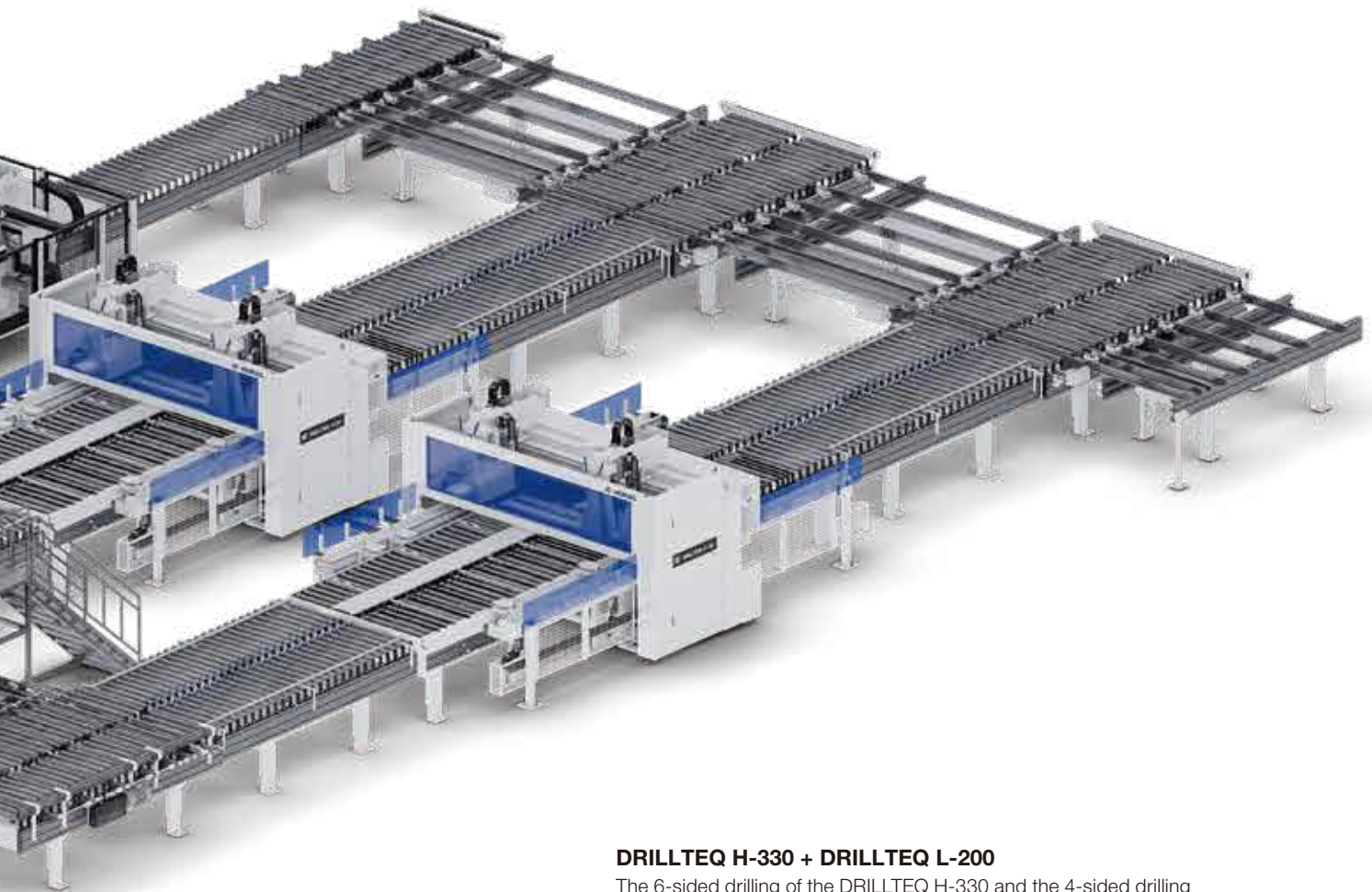

### DRILLTEQ H-330 + DRILLTEQ L-200

The 6-sided drilling of the DRILLTEQ H-330 and the 4-sided drilling of the DRILLTEQ L-200 incl. fitting setting is the perfect combination. The high efficiency and the fully comprehensive processing of the workpieces perfectly complement these three machines in combination.

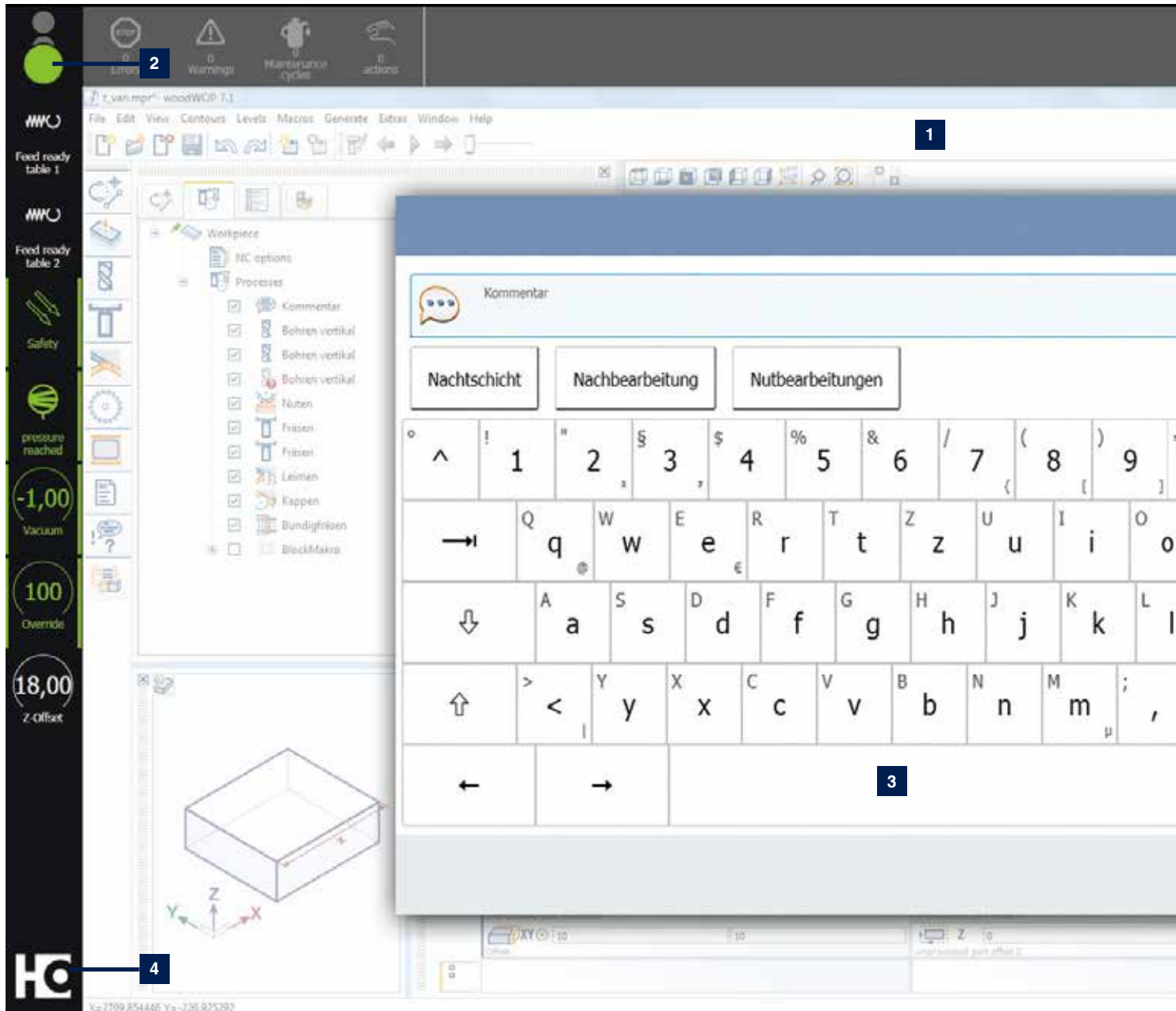

**1** The powerTouch2 screen is clearly structured. You can see all the important information at a glance, but you still have all the details.

**3** A functional pop-up keyboard that can be kept open, including automatic word completion for faster entries (when you enter the first letters, frequently used applications are proposed and you can select them directly).

**2** We have also improved the traffic light dialog further. You can now directly influence the machine's production readiness by selecting actions via the traffic light icon.

**4** Enhanced "Start" menu with additional information displayed (e.g. an indication of how many messages are currently pending or status bars that show the progress of the application) and direct access to actions (e.g. confirmation of actions without having to jump to the application).

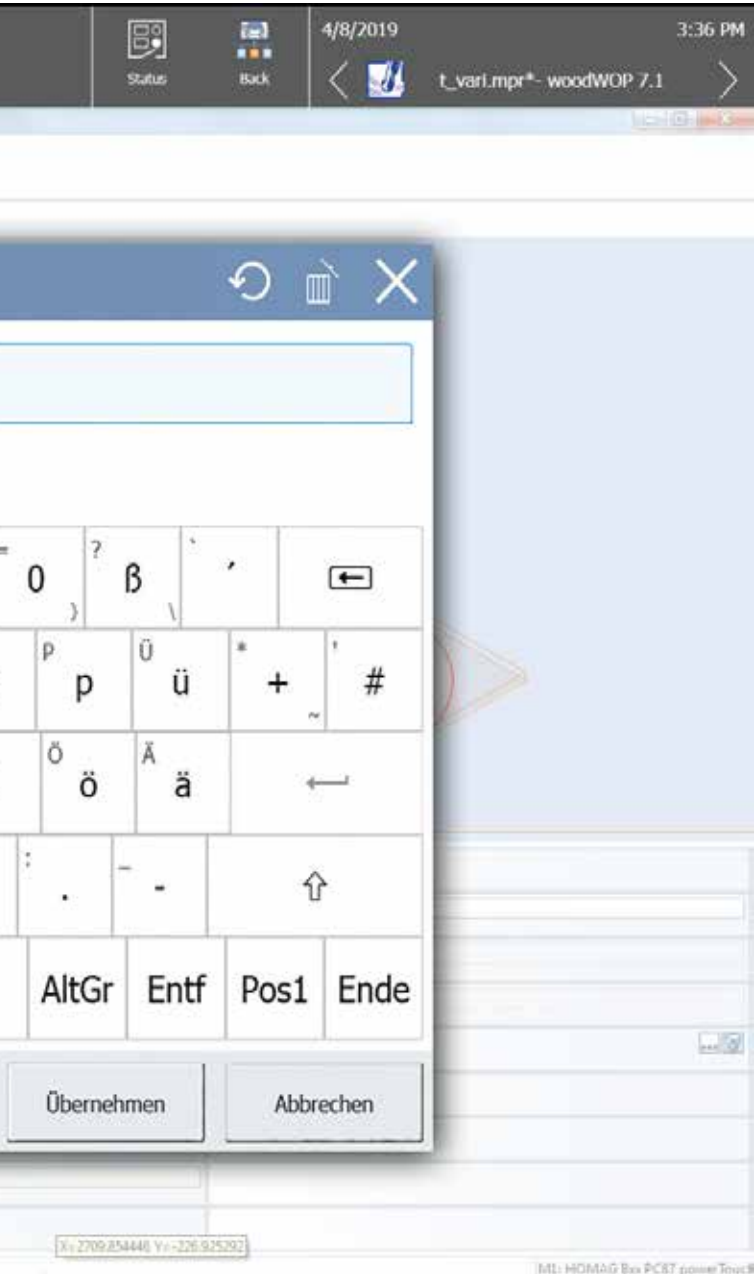

## The next generation of powerTouch: **powerTouch2**

Faster, more comfortable, clearer: Enjoy the benefits of our further improved powerTouch user interface. We have optimized our standardized operating concept and further adapted it to our customers' requirements. Controlling your HOMAG machines is now even faster and more intuitive. The new, modern design has a clear structure. The innovative touch operation allows you to achieve the desired result easily and comfortably.

With the new powerTouch generation, you can enter information at your machine even more quickly. Compared to the previous version, you can achieve a time saving of up to 30%. This is possible thanks to new features, such as automatic word completion, a pop-up keyboard that can be kept open and Windows-like functions, such as the selection of common actions directly via the start button.

Our successful powerTouch philosophy – **standardized, simple, ergonomic, evolutionary** – consistently further developed



**THE HIGHLIGHTS AT A GLANCE:**

- Direct and efficient operation, up to 30% faster
- Clearer and more informative thanks to additional information and live illustrations instead of program icons
- New applications for operating and controlling machines and systems (e.g. NCCenter in the PC87 control system on CNC machines or woodCommander 4 on throughfeed machines)
- Fresh, attractive design, based on the new HOMAG machine design

# All inclusive – Software

**WITH THIS SOFTWARE PACKAGE YOU ARE »READY TO RACE«.** You will receive one of the most established CNC-programming systems, the woodWOP software, which has proven itself by more than 30.000 installations worldwide.

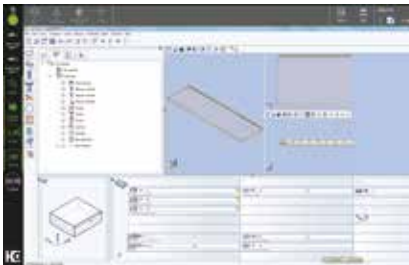

## woodWOP | License Machine

- Fast and intuitive operation thanks to simple, direct navigation
- Quickly create individual subprograms
- Increased programming security through 3D images of workpieces, processing and clamping equipment



## PulseCloud ready

Do you need support with Dashboard, Machine management, Tool management or Simple preventive maintenance? We know it and are at your side. MMR Basic provides a direct connection to the PulseCloud. Data is provided at a glance. Your fast support is guaranteed.

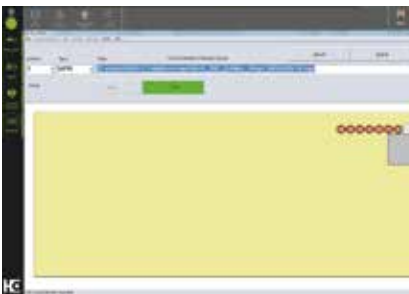

## Slot assignment

- Simple control of main machine functions through soft keys
- Graphical configuration
- Automatic mirroring of workpieces



## woodWOP DXF Basic

- Interface for CAD-Data Import
- Basis to generate woodWOP programs



## Machine data acquisition MMR Basic

- Record quantities and actual operating times on the machine
- Integrated maintenance instructions for optimum time and quantity-based planning, as well as performing maintenance



## HOMAG China - Your local contact



Office building

The HOMAG Group has been active in China for over 40 years and can therefore look back on a great deal of experience in the world's largest furniture market. A nationwide organization with over 700 employees including engineering, production, sales and service is spread over five regional branches. Short distances to our customers ensure efficiency and sustainability.

In addition to machines, the HOMAG Group offers complete solutions with software and digital tools.

The goal is to support our customers and the Chinese market on their way to a smart value chain in terms of quality, automation, end-to-end processes and the latest technologies.



Assembly line



Good structured order transaction

# HC LIFE CYCLE SERVICES

The sale of our machines comes with all-in optimum service backup and individual advice. We support you with service innovations and products which are especially tailored to your requirements. With short response times and fast

customer solutions we guarantee consistently high availability and economical production – over the entire life cycle of your machine.



## REMOTE SERVICE

- Hotline support via remote diagnosis by our trained experts regarding control, mechanics and process technology. Thus, more than 90% less on-site service required and consequently a faster solution for you!
- The ServiceBoard App helps to solve tasks in a fast, simple and concrete way. This is achieved by mobile live video diagnosis, automatic sending of service requests or the online spare parts catalog eParts.

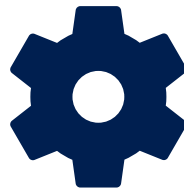

## SPARE PARTS SERVICE

- High spare parts availability and fast delivery.
- Ensuring quality by predefined spare parts and wear parts kits, comprising original spare parts.
- Identify and inquire for spare parts online under [www.eParts.de](http://www.eParts.de) 24/7, or buy even faster and more comfortably in the new HOMAG Webshop eCommerce.



## MODERNIZATION

- Keep your machinery up to date and increase your productivity as well as your product quality, This is how you can meet tomorrow's requirements today!
- We support you with upgrades, modernization as well as individual consultancy and developments.



## DIGITAL SERVICES

- ISN (intelliServiceNet) – The new remote service solution of the future! Fast restart of production because the remote service employee has extensive access to relevant physical data.
- intelliAdvice App – provides help for self-help. The preventive solutions proposed in the new App are the combination of our experiences and existing machine data.



## SOFTWARE

- Telephone support and consultancy through software support.
- Digitalization of your spare parts via 3D scanning saves time and money compared to new programming.
- Subsequent networking of your machinery with intelligent software solutions ranging from construction to production.



## FIELD SERVICE

- Increased machine availability and product quality by certified service staff.
- Regular checks through maintenance / inspection guarantee the highest quality of your products.
- We offer you the highest availability of technicians in order to reduce downtimes in case of unpredictable troubles.



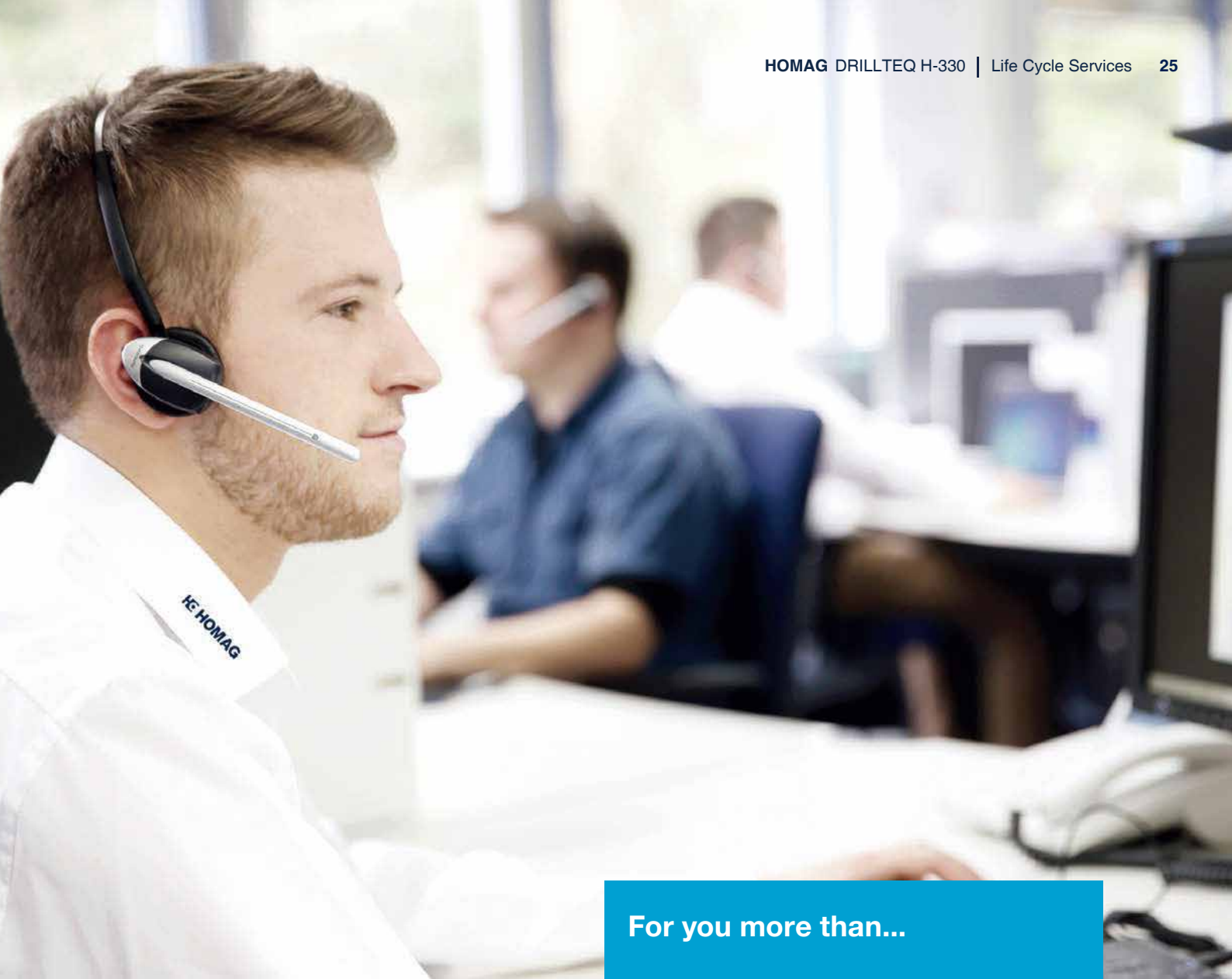

For you more than...

**1,350**

service employees worldwide

**90 %**

less on-site service thanks to successful remote diagnosis

**5,000**

customer training sessions per / year

**150,000**

machines, all electronically documented in 28 different languages – in eParts

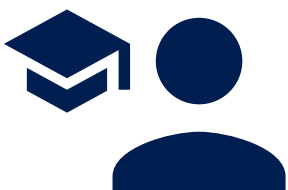

**TRAINING**

- . Thanks to training perfectly suited to your requirements, your machine operators can optimally operate and maintain the HOMAG machines.
- . The training also include customer-specific training documents with exercises proven in practice.
- . Online training and webinars. Learn without traveling, meet your trainer in the digital classroom.



TECHNICAL DATA		
<b>Footprint</b>		
<b>L</b>	mm	5,910 / 7,150
<b>W</b>	mm	3,600
<b>H</b>	mm	2,530
<b>Workpiece dimension</b>		
Length	mm	250 - 3000
Width ( single part )	mm	60 (40) - 1,250
Width ( double parts )	mm	2 x 620
Hight	mm	8 - 40
<b>Drilling Head TOP 1 &amp; 2</b>		
vertical spindles	Qty	2 x 13
vertical spindle clamping	Patented	Yes
horizontal spindles in X+/X-	Qty	2 x (3X+/3X-)
horizontal spindles in Y+/Y-	Qty	2 x (3Y+/3Y-)
Frequency controlled	RPM	1,250 - 7,500
<b>Drilling Head Bottom 1 &amp; 2</b>		
vertical spindles	Qty	2 x 8
vertical spindle clamping	Patented	Yes
Frequency controlled	RPM	1,250 - 7,500
<b>Dust extraction</b>		
Diameter	mm	4 x 160
<b>Electric</b>		
max. connection load	KW	38.5
<b>Air</b>		
Compressed Air	bar	7
<b>Machine</b>		
approx. weight	KG	4,800

OPTIONS		
<b>Router</b>		
Frequency controlled	RPM	18,000
Power	KW	3.5
Collet	Type	ER25
<b>Spindle for auto tool change</b>		
Frequency controlled	RPM	24,000
Power	KW	4.5
Collet	Type	HSK-F63
<b>Tool changer</b>		
Type		Linear
Fold	Qty	4
Max. tool weight	Kg	5
<b>Infeed</b>		
Type		Air-cushion table
Type		Self-aligning roller conveyer
<b>Outfeed</b>		
Type		Support table
Type		Driving roller conveyer

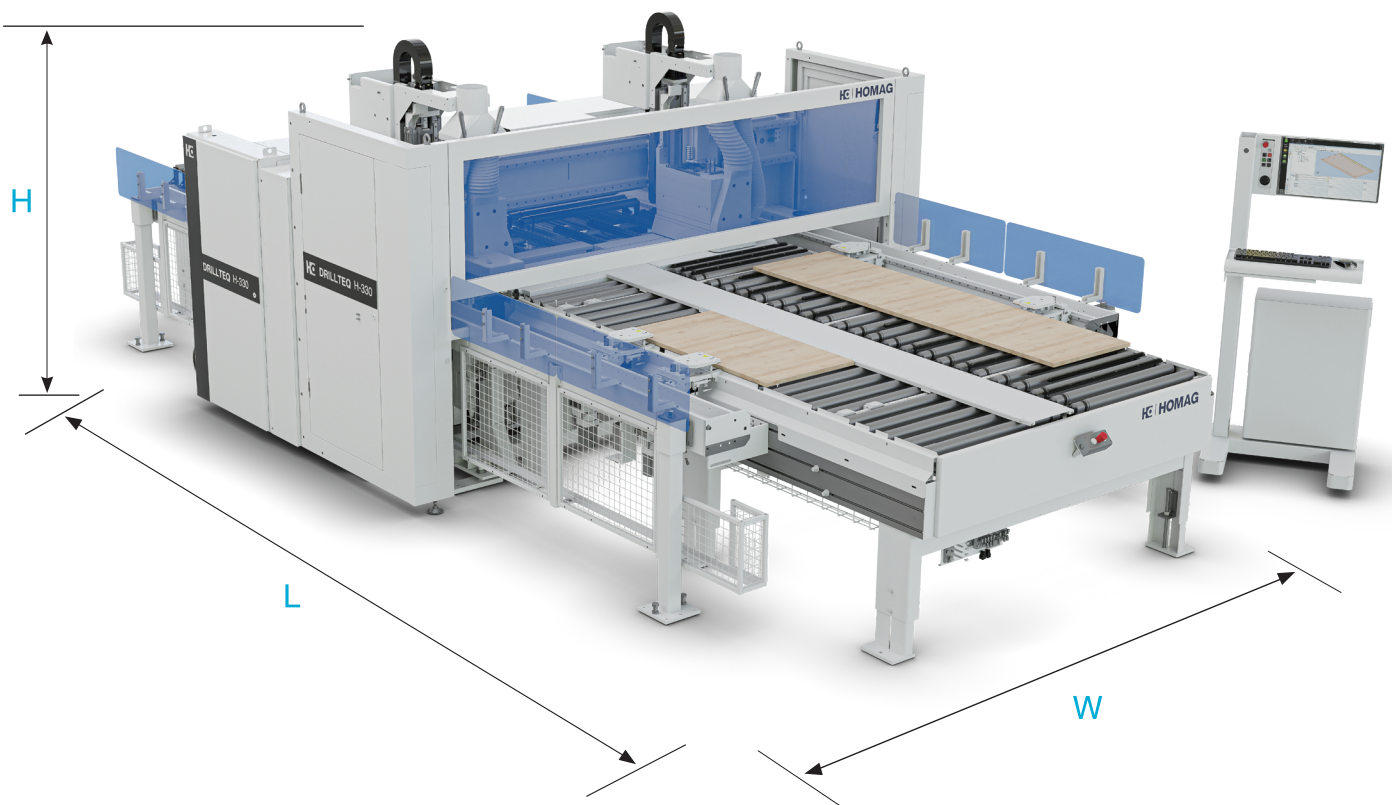



**HOMAG Group AG**  
marketing-chn@homag.com  
www.homag.com

**YOUR SOLUTION**

DRILLTEC H830 | 2023/08/23 | 本手册所含图片中可能会显示订单中未包含的选项。所列参数数据均基于我们在实验室及客户工厂实际结果得出, 基于生产条件的变化会有一些差异。霍迈公司保留对技术更改、印刷错误和勘误的权利。如有更改, 恕不另行通知。